

INDUSTRY PUBLIC UTILITIES COMMISSION CITY OF INDUSTRY

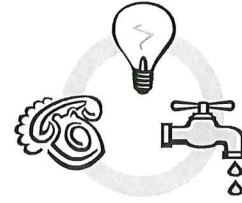

REGULAR MEETING AGENDA
SEPTEMBER 13, 2018 8:30 A.M.

President Mark D. Radecki
Commissioner Abraham N. Cruz
Commissioner Catherine Marcucci
Commissioner Cory C. Moss
Commissioner Newell W. Ruggles



Location: City Council Chamber, 15651 East Stafford Street, City of Industry, California

Addressing the Commission:

- ▶ **Agenda Items:** Members of the public may address the Commission on any matter listed on the Agenda. Anyone wishing to speak to the Commission is asked to complete a Speaker's Card which can be found at the back of the room and at the podium. The completed form should be submitted to the City Clerk prior to the Agenda item being called and prior to the individual being heard by the Commission.
- ▶ **Public Comments (Non-Agenda Items):** Anyone wishing to address the Commission on an item not on the Agenda may do so during the "Public Comments" period. In order to conduct a timely meeting, there will be a three-minute time limit per person for the Public Comments portion of the Agenda. State law prohibits the Commission from taking action on a specific item unless it appears on the posted Agenda. Anyone wishing to speak to the Commission is asked to complete a Speaker's Card which can be found at the back of the room and at the podium. The completed card should be submitted to the City Clerk prior to the Agenda item being called and prior to the individual being heard by the Commission.

Americans with Disabilities Act:

- ▶ In compliance with the ADA, if you need special assistance to participate in any City meeting (including assisted listening devices), please contact the City Clerk's Office (626) 333-2211. Notification of at least 48 hours prior to the meeting will assist staff in assuring that reasonable arrangements can be made to provide accessibility to the meeting.

Agendas and other writings:

- ▶ In compliance with SB 343, staff reports and other public records permissible for disclosure related to open session agenda items are available at City Hall, 15625 East Stafford Street, Suite 100, City of Industry, California, at the office of the City Clerk during regular business hours, Monday through Thursday 8:00 a.m. to 5:00 p.m., Friday 8:00 a.m. to 4:00 p.m. Any person with a question concerning any agenda item may call the City Clerk's Office at (626) 333-2211.

-
1. Call to Order
 2. Flag Salute
 3. Roll Call
 4. Public Comments

5. **BOARD MATTERS**

5.1 Consideration of the Register of Demands

RECOMMENDED ACTION: Approve the Register of Demands and authorize the appropriate City Officials to pay the bills.

5.2 Consideration of Change Order No. 1, for Industry Business Center East Side Street Light, Cabling, and Fiber Optic Substructure Plan, with Pacific Utility Installation, Inc. (Contract No. CITY-1430R)

RECOMMENDED ACTION: Approve Change Order No. 1, and authorize the Mayor to execute the Change Order.

5.3 Presentation by the Engineering & Compliance Manager of the La Puente Valley County Water District regarding the Industry Public Utilities Water Operations Report

RECOMMENDED ACTION: Receive and file the report.

6. Adjournment. Next regular meeting: Thursday, October 11, 2018 at 8:30 a.m.

INDUSTRY PUBLIC UTILITIES COMMISSION

ITEM NO. 5.1

INDUSTRY PUBLIC UTILITIES COMMISSION
AUTHORIZATION FOR PAYMENT OF BILLS
Board Meeting September 13, 2018

| <u>FUND</u> | <u>DESCRIPTION</u> | DISBURSEMENTS |
|-------------|---------------------------|---------------|
| 560 | INDUSTRY PUBLIC UTILITIES | 47,856.90 |

| <u>BANK</u> | <u>DESCRIPTION</u> | DISBURSEMENTS |
|-------------|--------------------------|---------------|
| BofA | BANK OF AMERICA CHECKING | 47,856.90 |

APPROVED PER ACTING CITY MANAGER

**Industry Public Utilities Commission
Board Meeting
September 13, 2018**

| Check | Date | | | Payee Name | Check Amount |
|--|---------------|------------|--|----------------------------------|--------------|
| IPUC.CHK - IPUC Water BofA Checking | | | | | |
| 40389 | 08/16/2018 | | | SO CALIFORNIA EDISON COMPANY | \$40,659.89 |
| | Invoice | Date | Description | Amount | |
| | 2019-00000152 | 08/01/2018 | 06/29-07/31/18 SVC - 1991 WORKMAN MILL U | \$40,659.89 | |
| 40390 | 09/13/2018 | | | INDUSTRY PUBLIC UTILITIES COMMIS | \$2,000.00 |
| | Invoice | Date | Description | Amount | |
| | AUG-18 | 09/05/2018 | REIMBURSE PAYROLL - AUGUST 2018 | \$2,000.00 | |
| 40391 | 09/13/2018 | | | ROWLAND WATER DISTRICT | \$5,197.03 |
| | Invoice | Date | Description | Amount | |
| | I-7312018-A | 08/06/2018 | CONTRACT SVC - JULY 2018 | \$3,262.38 | |
| | I-7312018-B | 08/06/2018 | CONTRACT SVC - JULY 2018 | \$1,934.65 | |

| Checks | Status | Count | Transaction Amount |
|--------|--------|-------|--------------------|
| | Total | 3 | \$47,856.92 |

INDUSTRY PUBLIC UTILITIES COMMISSION

ITEM NO. 5.2



INDUSTRY PUBLIC UTILITIES COMMISSION

MEMORANDUM

TO: Honorable President Radecki and Commission Board Members

STAFF: Troy Helling, Acting Public Utilities Director *TH*

FROM: Joshua Nelson, Contract IPUC Engineer, CNC Engineering *JN*
Gerardo Perez, Construction Manager, CNC Engineering *GP*

DATE: September 13, 2018

SUBJECT: Consideration of Change Order No. 1, for Industry Business Center East Side Street Light, Cabling, and Fiber Optic Substructure Plan, with Pacific Utility Installation, Inc., Contract No. CITY-1430R

Background:

On April 13, 2017, the Industry Public Utilities Commission ("IPUC") awarded Contract No. CITY-1430R, Industry Business Center East Side Street Light, Cabling, and Fiber Optic Substructure Plan, in the amount of \$695,880.00 to Pacific Utility Installation, Inc. The project consisted of construction, installation and procurement of a 12kV Distribution System, streetlights, fiber optic substructures and associated equipment which included placement of the electrical wire, street light foundations, pole erections, electrical wire pulling, the installation of light bulbs, fiber optic pull boxes and conduit, and the testing and commissioning of the IPUC System streetlights to ensure safe and reliable operation of the 12kV distribution system, streetlights and associated equipment.

After the contract was awarded, additional work was added to the contract. As of August 30, 2018, the Contract City Engineer reviewed the following change order for completeness and accuracy as to the materials and labor included:

Change Order No. 1 – As part of the Industry Business Center reclaimed water system, Walnut Valley Water District will construct a booster pump station on the east side of Grand Ave. This booster pump station will provide the necessary pressure to the irrigation system for the 600 acres. The booster pump station requires electrical power and therefore, the Contractor was asked to submit a cost proposal based on Butsko's (electrical consultant) design. The Contractor submitted a cost proposal in the amount of \$40,750.00 which includes furnishing and installing a 500KVA pad mounted transformer and approximately 670 lineal feet electrical cable.

Discussion:

On April 13, 2017, the City Council appropriated \$695,880.00 to the Project and appropriated a contingency allowance in the amount of \$69,588.00, for unforeseen changes and an additional amount of \$69,588.00 for contract administration and inspections services. The funds in the amount of \$835,056.00 were budgeted as part of the Electric Utility Reserves Fund General Fund – Construction Costs (Account No. 120.702.5205).

The table below details the complete project costs for CITY-1430R.

| | |
|---|---------------------|
| Contract (Pacific Utility Installation) | \$695,880.00 |
| Change Order No. 1 | \$40,750.00 |
| Total Project Cost | \$736,630.00 |

Fiscal Impact:

Revised project costs are **\$736,630.00**. Funds appropriated for this project include the contract cost in the amount of \$695,880.00 plus \$69,588.00 for unforeseen changes which total \$765,468.00. Therefore no additional funds are required.

Recommendation:

- 1.) Approve Change Order No. 1 in the amount of \$40,750.00 and authorize the Mayor or his designee to execute the approved change order.

Exhibits:

- A. Change Order No. 1 dated 9/13/18

TH/JN/GP:as

EXHIBIT A

Change Order No. 1 dated 9/13/18

[Attached]

CITY OF INDUSTRY

CHANGE ORDER

15651 E. Stafford St.
 City of Industry, CA 91744
 (626)333-2211

Change Order No. 1

Industry Business Center East Side
 Street Light, Cabling, Fiber Optic
Project Structure Plan **Contract No.** CITY-1430R **Date** September 13, 2018

Type
Project Street Lights/Cabling **Contractor** Pacific Utility Installation, Inc.
Location City of Industry

Explanation:

Installation of a 500KVA pad mounted transformer and approximately 670 lineal feet electrical cable for the booster pump constructed by Walnut Valley Water District on the east east side of Grand Avenue to provide the necessary pressure to the irrigation system for the 600 acres.

Extra Work by: Contract Items X Negotiated T & M

The contractor is hereby directed to perform all labor and to provide all materials necessary to carry out the work described below:

| ITEM NO. | ITEM | QUANTITY | UNIT PRICE | TOTALS (\$) | |
|-------------------|--|----------|------------|--------------------|---|
| | | | | + | - |
| 1 | 500KVA Pad & 670 Lineal ft. Electrical Cable | 1 | LS | \$40,750.00 | |
| TOTAL COST | | | | \$40,750.00 | |

T & M SUMMARY

| | | | | |
|---|---------------|----------------------|------------------------------------|--------------------------|
| *Labor Cost | | | Total Labor per Day | |
| *Equipment Cost (See attached breakdown) | | | Total Equipment per Day | |
| *Material Cost | | | Sub-Total | \$ - |
| (*Attach breakdown of labor, equipment and materials) | | | Other Additive (Profit & Bond Fee) | |
| CHANGE ORDER SUMMARY | | % of Contract Amount | Total T & M | \$ - |
| Original Contract Amount | \$ 695,888.00 | | Pay This CHANGE ORDER | \$40,750.00 5.86% |
| Total Previous Change Orders | \$ - | 0.0000% | | |
| Total Change Orders | \$ 40,750.00 | 5.86% | | |

Authorized by _____ Additional Contract Days 30

I hereby certify that the quantities shown and/or amounts shown for equipment, material and labor costs (if any) are correct to the best of my knowledge and the total cost shown above shall be considered final payment for the work specified by this change order. The total cost includes compensation for any delay in the preparation of this change order and the time to complete the specified work.

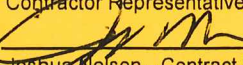
 Contractor Representative 8-29-18 Date

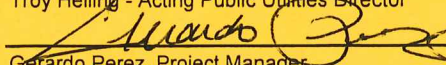
 Joshua Nelson - Contract IPUC Engineer 8/30/18 Date

Troy Helling - Acting Public Utilities Director 8/27/18 Date

 Gerardo Perez, Project Manager 8/27/18 Date

RCMU Extension

to

Pacific Utility Installation 8/9/18

~~Merton Business Park~~

| ELECTRIC CABLING & EQUIPMENT - IBC Pump Station (Includes all necessary traffic control per City requirements, switching, testing, and energizing per IPUC requirements.) | QTY | | UNIT PRICE | TOTAL |
|--|-----|----|--------------|--------------|
| Pad Mount Transformer (ABB, Howard, or GE: 500 KVA, 12KV/277-480 Volt, Switched, Fused, with Taps) | 1 | EA | \$ 20,000.00 | \$ 20,000.00 |
| 3/C 1/0 XLP-JCN, 220MIL, 15KV | 670 | LF | \$ 15.00 | \$ 10,050.00 |
| 200A Loadbreak Elbows, 15 KV with Test Points | 12 | EA | \$ 300.00 | \$ 3,600.00 |
| 200A 4 Way Load Break Junction Bars, 15 KV | 3 | EA | \$ 1,000.00 | \$ 3,000.00 |
| 200A Insulating Recepticles, 15 KV with Test Points | 6 | EA | \$ 400.00 | \$ 2,400.00 |
| Ground Assembly, Hooks, & Racking (at each new structure) | 2 | EA | \$ 250.00 | \$ 500.00 |
| 4/C 3-700 & 1-350 AL-CLP, 600V (with connections). Service: 2 runs @ 40' each with tails. | 80 | LF | \$ 15.00 | \$ 1,200.00 |

TOTAL BID PRICE

\$ 40,750.00

CABLE PRELIMINARY BY UNIVERSITY OF SOUTHERN CALIFORNIA; MECHANICAL DESIGN BY BUSINESS CENTER; HYDRAULIC DESIGN BY BUTSKO; PUMP AND TREATMENT SIEE BIDDING PLAN FOR 10-15-2018; 11/15/2018; 10:28 AM '18

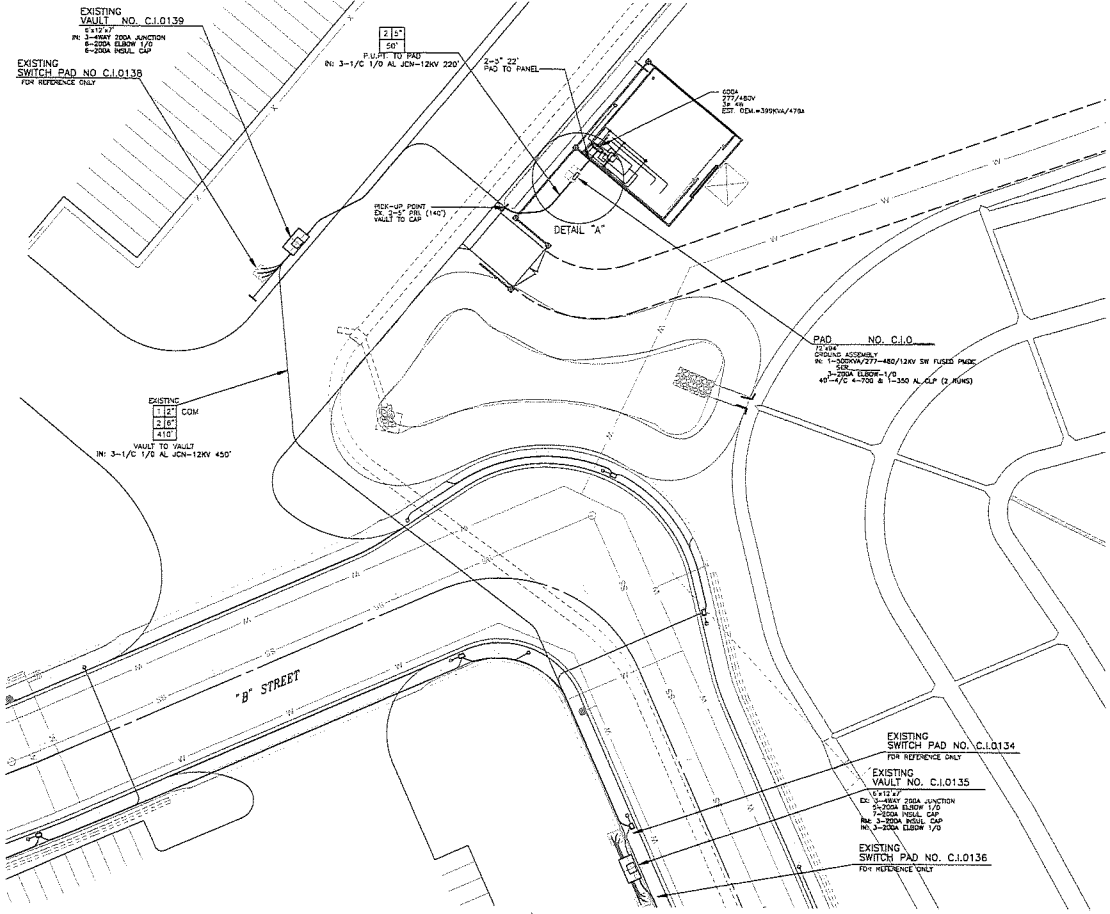
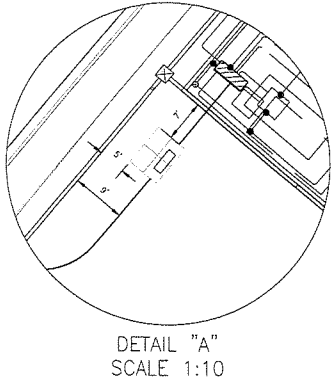

BID SET

| | | | | | |
|--|---------------------|------------------------|---------------|---------|----------------|
| SUCCESSOR AGENCY TO THE INDUSTRY URBAN-DEVELOPMENT AGENCY | | | | | |
| APPROVED BY: | | | | | |
| ELMONT N. GALVILA P.E. | ARCHT. ENGINEER | DATE | PAGE # | PROJ. # | EXPIRE (MONTH) |
| IBC BOOSTER PUMP STATION ELECTRIC CABLE PLAN | | | | | |
| ELECTRIC PLAN | | | | | |
| DESIGN BY: C.B. | CHECKED BY: D.A.P. | JOB NO.: | SHEET: 2 OF 2 | | |
| DRAWN BY: C.B. | DATE: JULY 10, 2018 | CONTRACT NO.: IBC-0396 | | | |

| NO. | DATE | REVISIONS | DR. BY |
|-----|------|-----------|--------|
| | | | |
| | | | |
| | | | |
| | | | |

BUTSKO
 UTILITY DESIGN, INC.
 AN SDC COMPANY
 20415 SEPERSCH AVENUE SUITE 1
 MANHETTA, CA 92560
 TEL: 951-634-9920 FAX: 951-634-9930
 WWW.BUTSKOUTILITY.COM